

Installation and Maintenance Manual

Model 2010-PIV

Resilient Seat Post Indicator Gate Valve

AWWA C515

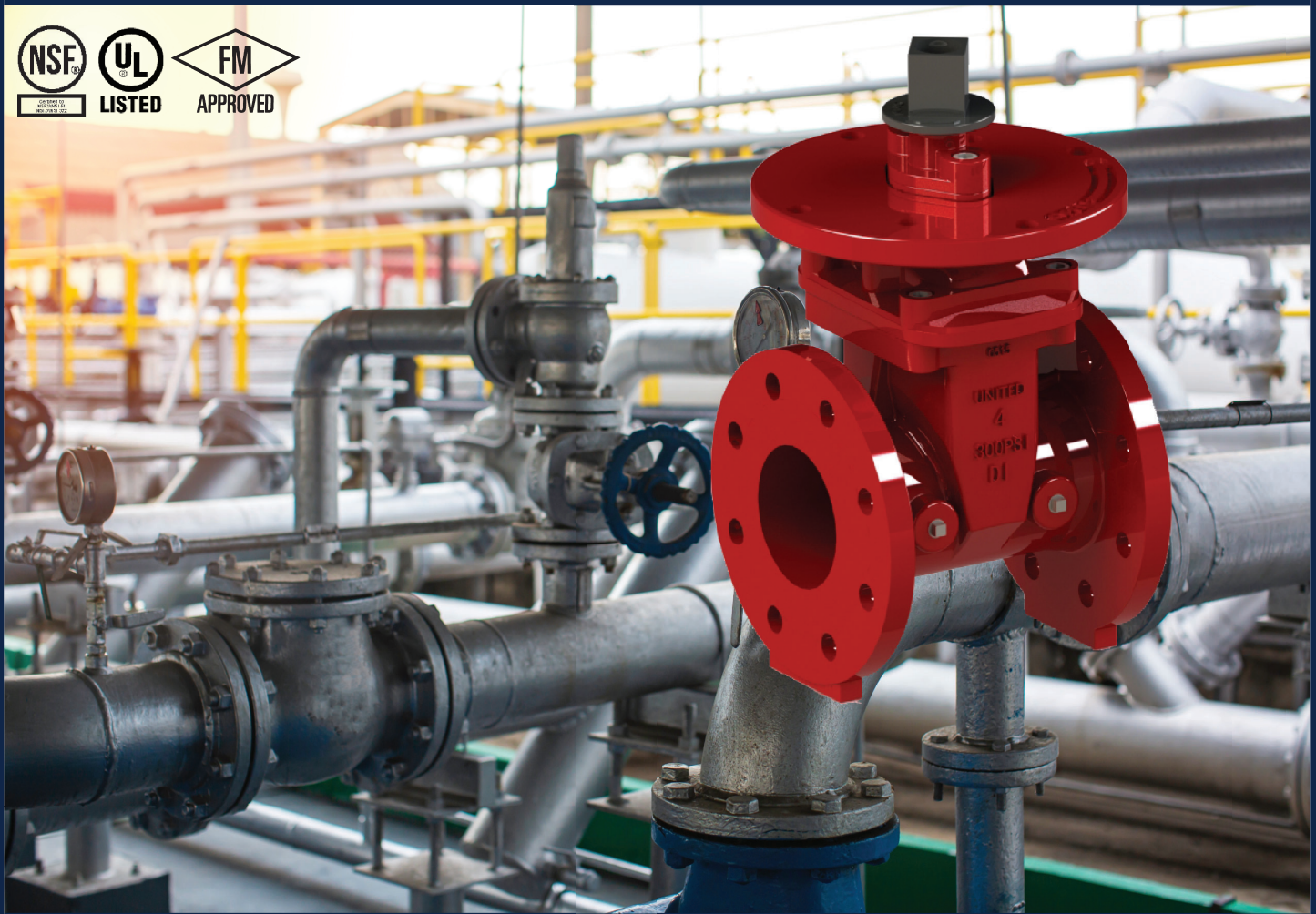

MODEL 2010-PIV - Post Indicator Valve

Item No.	Description	Material
1	Body	ASTM A536 65-45-12
2	Wedge	EPDM Coated DI
3	Stem Nut	ASTM B62 C83600
4	Stem	AISI 420
5	Bonnet Bolts	ASTM A307B
6	Gasket	EPDM
7	Bonnet	ASTM A536 65-45-12
8	Thrust Collar	ASTM B62 C83600
9	O-ring	EPDM
10	Gland	ASTM A536 65-45-12
11	O-ring	EPDM
12	Dirt Seal	EPDM
13	Washer	ASTM A307B
14	Bolt	ASTM A307B
15	Operating Nut	ASTM A536 65-45-12
16	Bolt	AISI 316
17	Post Ind. Flange	EPDM
18	Plug	ASTM B16 36000

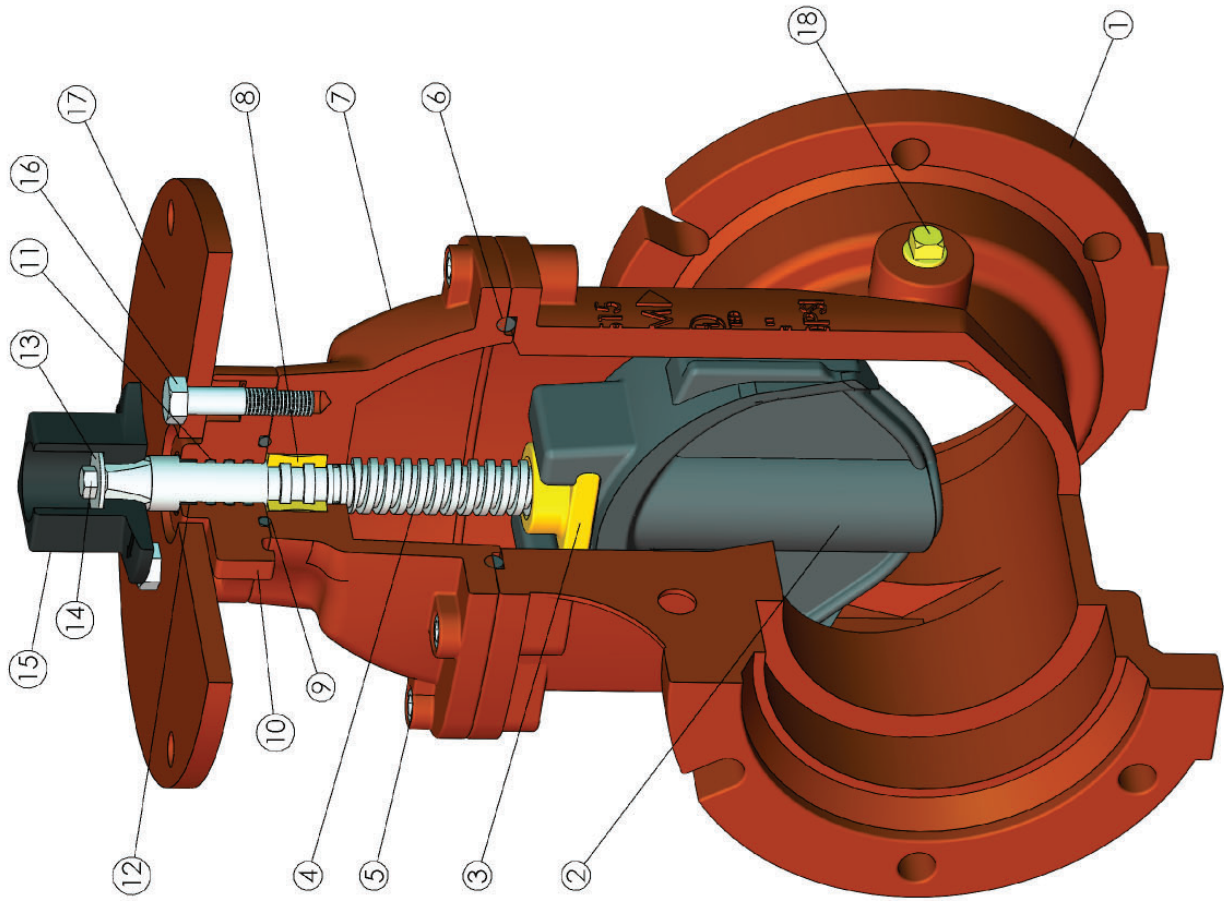

LAYOUT AND SITING

At the design stage, it should be considered where valves will be located in order to allow access for operation, adjustment, maintenance and repair. Outside screw-and-yoke valves (OS&Y) require space above the valve to accommodate the rising stem.

Valves must be provided with adequate support. Adjoining pipe-work must be supported to avoid the imposition of pipeline strains on the valve body, which would impair its performance or crack the valve body. Heavy valves may need independent support or anchorage.

Gate valves may be installed in:

- a) Horizontal pipe-work with stem in the vertical position.
- b) Vertical pipe-work with stem in the horizontal position.

The valve should not be installed in horizontal pipe-work with the stem in the horizontal position, because shut-off performance may be impaired. In the best interest of safety concerns, valves installed for end-of-line service and opened infrequently should be fitted with a locking device on the operating mechanism. Otherwise, they should be fitted with a UNITED Blind Flange on the downstream flange of the valve.

INSTALLATION

(See AWWA C600: Figure 3, for mechanical-joint assembly).

Prior to installation, a check of the identification plate and body marking must be made to ensure that the correct valve is being installed.

Valves should not be subjected to misuse such as careless handling, allowing dirt to enter the valve through the end ports, lack of cleaning both the valves and system before operation, and using excessive force during bolting and hand-wheel operation.

All special packaging material must be removed before beginning the installation process.

Valves must be provided with adequate support. Adjoining pipe-work must be supported to avoid the imposition of pipeline strains on the valve body, which would impair its performance or crack the valve body.

Valves should not be lifted by means of the hand-wheel or the stem.

Immediately prior to valve installation, the pipe-work to which the valve is to be fastened should be inspected to ensure that it is clean and free of debris. Valve end caps should only be permanently removed just before installation.

Each valve interior should be inspected through the end ports to determine that it is clean and free from foreign matter. The mating flange (both valve and pipe-work flanges) should be examined for correct gasket contact face, surface finish, and condition. If a condition is found which would potentially cause leakage, final assembly should not be attempted until the condition is corrected.

The gaskets should be suitable for operating conditions and maximum pressure/temperature ratings. The gaskets should be inspected to ensure freedom from defects or damage.

The following steps should be taken to ensure correct alignment of the flanges being assembled. First, the installer should ensure that the initial contact of flange and gasket is parallel and that the faces are uniform. Then, the bolts should be tightened progressively by means of a crisscrossed pattern and should be repeated until all bolts are adequately tightened.

Parallel alignment and concentricity of flanges are especially important in the event of assembling a valve into an existing system; misalignment could cause damage to the valve body.

Flanged joints depend on compressive deformation of the gasket material between the flange surfaces. Thus, the bolting must be checked for correct size, length, material and that all connection flange bolt holes have been utilized.

At the conclusion of installation and before operating, all deposits or foreign material shall be removed from the equipment.

OPERATING

The valve is opened by counterclockwise rotation of the UNITED Model 5400 Ground Post Indicator to a positive stop without further effort. When fully open, it is advantageous to rotate Ground Post Indicator clockwise 1/2 turn. To close the valve, the Ground Post Indicator is rotated clockwise to a positive stop.

Note: When the valve is closed at extreme high temperature and then cooled, the wedge may become tight in the valve and found difficult to open. Conversely, a valve closed at room temperature can be difficult to open if there is an increase in fluid temperature causing a linear expansion of the stem, which may tighten the wedge further into the body seat.

The operator should use suitable hand protection at extreme temperature conditions.

The valve should only be used in the open or closed position. Regulating or throttling service should be avoided.

MAINTENANCE

The valve should be at zero pressure and ambient temperature prior to any maintenance.

Maintenance personnel must use tools and equipment applicable for resilient-seated gate valves. Tools causing sparks are only permissible as long as no volatile conditions are present.

A full risk assessment must be undertaken prior to any maintenance. The assessment must take into account the possibility of exceeding the limits of use whereby a potential hazard could result. A maintenance program should therefore include checks on the development of unforeseen conditions, which could lead to failure.

In systems where corrosion is a potential hazard, wall thickness checks on the body and bonnet should be made. This requires either the removal of the valve from the pipeline or removal of the bonnet from the system at zero pressure. If the wall thickness has reduced by 25%, the valve must be replaced.